

ECE 471 – Embedded Systems

Lecture 20

Vince Weaver

`https://web.eece.maine.edu/~vweaver`

`vincent.weaver@maine.edu`

20 October 2023

Announcements

- HW#6 was due
- HW#7 will be posted today
- Midterms will be returned Monday hopefully
- Hand out SPI hardware
- Hold on to your LED displays (and these temperature probes) until after Homework #9
- I'll be teaching ECE435 and ECE574 in the Spring



SPI bus

- Serial Peripheral Interface Bus
- Synchronous full-duplex serial bus named/formalized by Motorola. No real standard.
- What does serial mean? (one bit at a time)
- What does synchronous mean? (Separate clock line)
- What does full-duplex mean? (Transmit and receive at same time)



What used for?

- LCD displays
- Optional interface to SD cards
- LED strips
- JTAG debugging
- Analog Digital Converters



Hardware Setup

- Controller/Device with multiple device select lines
- 4-wire bus (plus power/ground)
- SCLK – serial clock (output from controller)
- MOSI – master out, slave in
- MISO – master in, slave out
Must be high impedance if more than one device



- CS0, CS1, etc – device chip selects

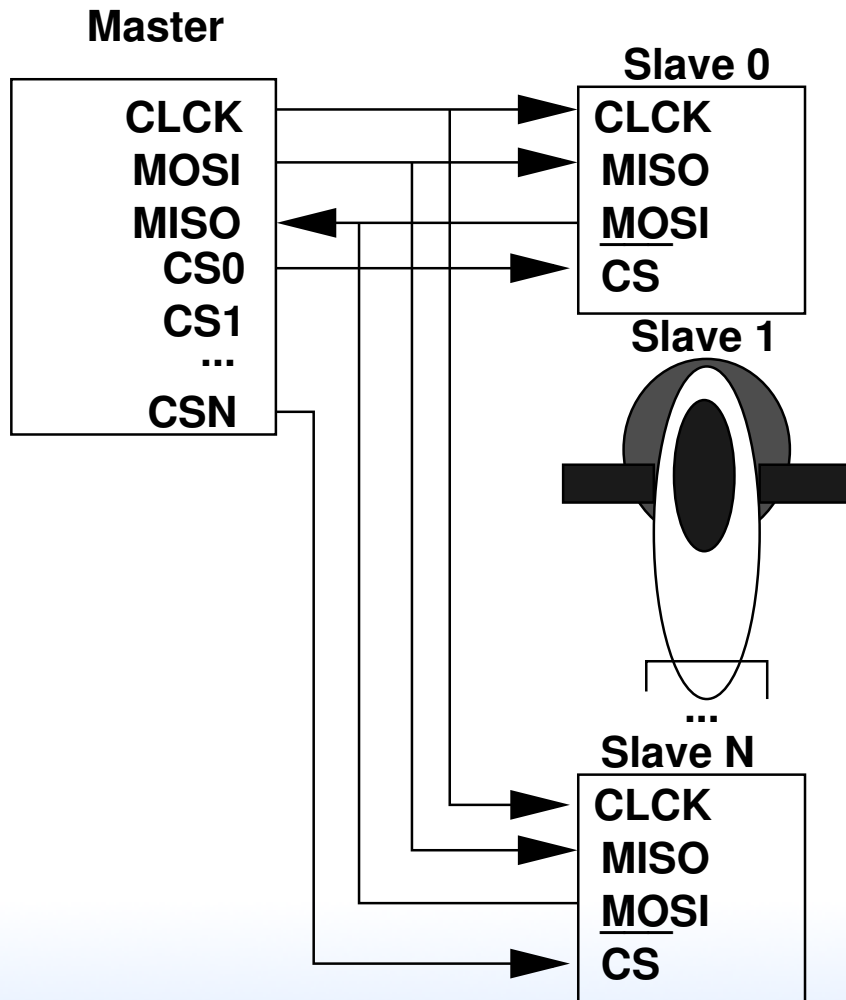

SPI protocol

- Controller pulls chip-select of desired device low
- Controller starts clock
No set speed, just what the device can handle.
Up to a few MHz (Pi in theory 128MHz, 16MHz more realistic)
- Must both Send *and* receive (at same time over MISO/MOSI wires)
Doesn't have to be useful data, but must be done both



ways

- Controller transmits data bits as long as it has it. When done turns off clock and maybe deselects device.
- It's basically just a shift register in the controller and device, and you rotate through enough bits to swap the values in each, then both sides can read out the transfer.

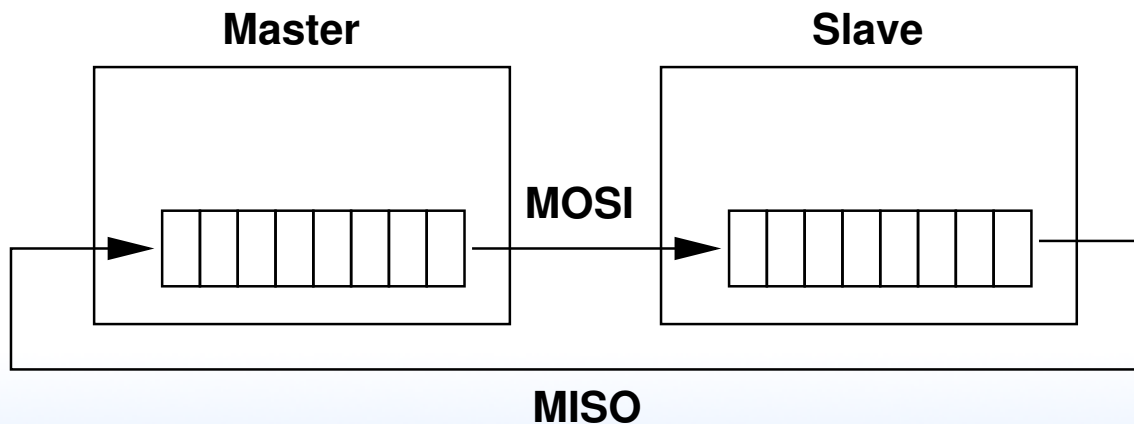

Clock Polarity/Phase

- Many have adopted Freescale's terminology
- CPOL=0 – base clock is zero
 - CPHA=0 – data captured on rising edge
 - CPHA=1 – data captured on falling edge
- CPOL=1 – base clock is one
 - CPHA=0 – data captured on falling edge
 - CPHA=1 – data captured on rising edge



- Also given as “mode” numbers, 0 - 3. CPOL/CPHA. This can vary by manufacturer. Check your data sheet!
- Timing diagram from Wikipedia (CC BY-SA 3.0)

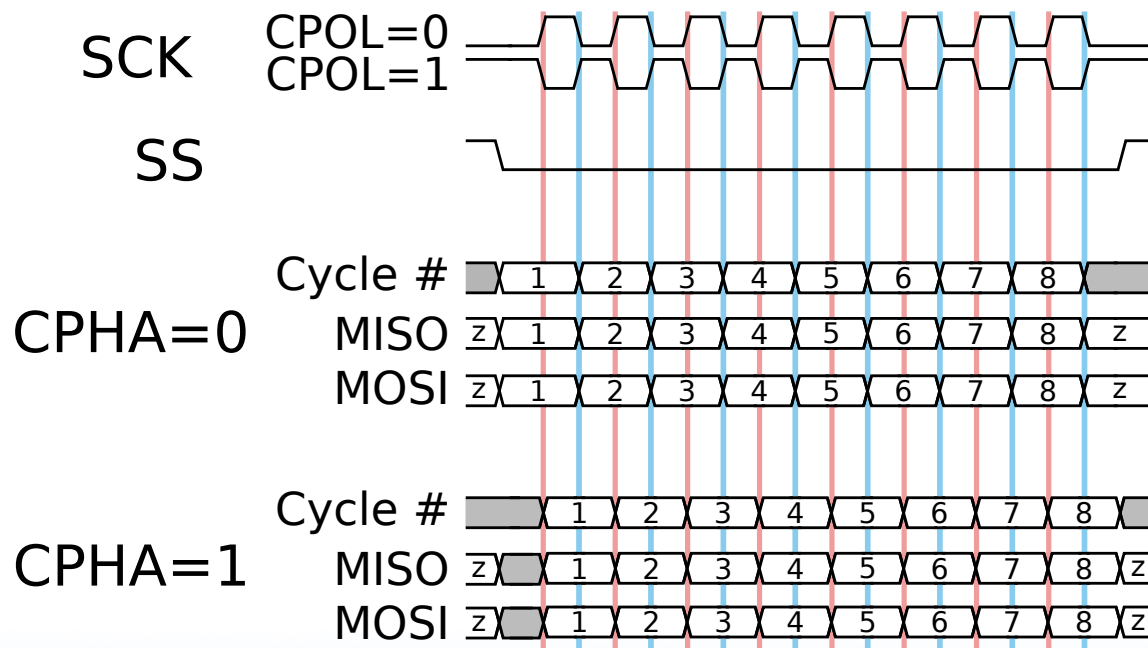

Connection

- “independent” – One device per select line
- “daisy-chain” – MISO to MOSI, like long chain of shift registers, only need one device select line.



Interrupts

- Possible... think touch screens and such. Not officially specified



Errors

- No way to indicate errors
- Some chips will ignore if invalid data sent (wrong number of bits) some not



SPI advantages

- Full-duplex
- fast (no set speed limit)
- arbitrary message size in bits
- low power (no pullup resistors)
- Simple implementation (can be just 74HC495 shift reg)
- no arbitration
- no unique ids
- unidirectional signals
- clock provided by master (no oscillator needed in slaves)



SPI disadvantages

- more pins (4 plus ground plus power plus one more each slave)
- short distances (10 feet or so?)
- no flow control
- no error reporting
- no standard



SPI vs i2c

- i2c benefits:
 - requires fewer wires
 - shared bus (no need for lots of chip select)
 - nack when data received
 - can have multiple masters
 - less susceptible to noise (some sites claim this)
 - can transmit longer distances (other sites claim this, probably varies with speed you're attempting)
 - has a formal standard



- spi benefits:
 - lower power
 - potentially faster, full-duplex
 - i2c can be brought down by one bad device (though SPI probably can too it's just less likely)



SPI bus on Raspberry Pi

- SPI1 is on the header
- Pin 23 – SCLK
- Pin 19 – MOSI
- Pin 21 – MISO
- Pin 24 – CE0
- Pin 26 – CE1
- Unlike some boards, no nIRQ (SPI interrupt) pin
- Also note on PI SCLK is generated from CPU clock so it might change if frequency scaling happens



SPI bus on Linux

- On recent Pis, SPI is enabled through devicetree. You can run `sudo raspi-config`, select interfaces, then SPI, then say yes to enable and at boot.
- On older systems you might have to do this manually by `modprobe spi-bcm2835`; even older kernels it has a different name: `modprobe spi-bcm2708`
- `dmesg | grep spi` will show useful debug
- To get the user interface `modprobe spidev`



SPI dev interface

- <https://www.kernel.org/doc/Documentation/spi/spidev>
- `/dev/spidevB.C` (B=bus, C=slave number).
On pi it is `/dev/spidev0.0`
- Other useful info in `/sys/devices/.../spiB.C`,
`/sys/class/spidev/spidevB.C`
- To open the device, do something like the following

```
spi_fd=open("/dev/spidev0.0",O_RDWR);
```



- To set the write mode, use ioctl:

```
int mode=SPI_MODE_0;
result = ioctl(spi_fd, SPI_IOC_WR_MODE, &mode);
```

Modes can be SPI_MODE_0 through 3, or else you can build them out of SPI_CPOL and SPI_CPHA values.

Current mode can be read back with SPI_IOC_RD_MODE

- To set the bit order, use ioctl:

```
int lsb_mode=0;
result = ioctl(spi_fd, SPI_IOC_WR_LSB_FIRST, &lsb_mode);
```

Current can be read with SPI_IOC_RD_LSB_FIRST

Get/Set if MSB is first (common) or LSB is first.

Empty bits padded to left with zeros no matter what the



setting.

- `SPI_IOC_RD_BITS_PER_WORD`, `SPI_IOC_WR_BITS_PER_WORD`
Number of bits in each transfer word. Default (0) is 8 bits.
- `SPI_IOC_RD_MAX_SPEED_HZ`, `SPI_IOC_WR_MAX_SPEED_HZ`
Set the maximum clock speed.
- By default using `read()` or `write()` on the device node will only do half-duplex.
- For full duplex support you need something like the



following:

```
#define LENGTH 3
int result;
struct spi_ioc_transfer spi;
unsigned char data_out[LENGTH]={0x1,0x2,0x3};
unsigned char data_in[LENGTH];

/* kernel doesn't like it if stray values, even in padding */
memset(&spi,0,sizeof(struct spi_ioc_transfer));

/* Setup full-duplex transfer of 3 bytes */
spi.tx_buf = (unsigned long)&data_out;
spi.rx_buf = (unsigned long)&data_in;
spi.len = LENGTH;
spi.delay_usecs = 0 ;
spi.speed_hz = 100000 ; // required
spi.bits_per_word = 8 ;
spi.cs_change = 0 ;

/* Run one full-duplex transaction */
result = ioctl(spi_fd, SPI_IOC_MESSAGE(1), &spi) ;
```

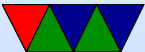

Zeroed Structs in Kernel ABI

- Why is the kernel erroring out if the empty “pad” bit not zero?
 - Forward compatibility. You want to make sure that any empty bits stay that way.
 - If you want to add new functionality in the future you have to ensure reserved bits are all zero, otherwise old programs will do unexpected things (or break) if they had been accidentally setting those bits.



- So why were the pad bits non-zero? Bad luck. Local struct allocated on the stack, so if there were old values on the stack the pad value could be non-zero.



Analog Digital Converters on Raspberry Pi

- Unlike many other embedded boards, the Pi has no A/D converters built in.
- You're stuck using SPI or i2c devices



MCP3008

- For HW#7 we'll use the MCP3008 8-port 10-bit SPI A/D converter
- up to 100ksp (samples per second)
- 2.7 to 5.5V
- 10-bits of accuracy
- 8 single-ended inputs (vs ground) or 4 “pseudo-differential” inputs (vs each other)



- Config sent in each request packet
- Clock frequency must be long enough that the A/D has time to convert
- $V_{IN} = \frac{value \times V_{REF}}{1024}$
Yes, this seems wrong (can never have full V_{REF} output)
but this is what the data sheet says to use



MCP3008 μ controller mode

- Datasheet describes way to easily use from a device
- Send 3 bytes. First has value '1' (start bit). The second has the top 4 bits being single/diff followed by 3 bits of channel you want. The rest is all 0s for padding.
- 00000001 SCC0000 00000000
- You read back 3 bytes. First 13 bits are don't care (ignore) followed by 0 then the 10 bits of sample.
- XXXXXXXXX XXXXX098 76543210



Getting 10 bits spread across two bytes into an integer

- You'll want to get the data in `data_in[1]` and `data_in[2]` combine it into 10 bits in an integer variable (which are usually 32 bits)
- You probably want to mask off the don't care bits in case they have extraneous 1s in them, recall that something like

```
x=x&0x7 // preserve bottom 3 bits, clear top to 0
```

in C can be used to mask off unwanted bits to 0



- To get the 2 bits from the 8-bit value up to bits 9 and 10 you'll want to shift left by 8, in C something like

```
y=char_value<<8;
```

- Then you can combine that with another 8 bit value by bitwise-oring or adding in the value
- If you're being really fancy you can put all 3 of the above steps in one line of code



TMP36

- Be sure you use the right chip, looks like a transistor, says TMP36 on it (not Dallas, that's the 1-wire chip)
- Linear temperature sensor
- The temperature can be determined with the following equation:

$$\text{deg}_C = (100 \times \text{voltage}) - 50$$

- Also the following might be useful:

$$\text{deg}_F = (\text{deg}_C \times \frac{9}{5}) + 32$$

- Be careful hooking up! If vdd/gnd switched it heats up



to scalding temperatures (the datasheet lists the pinout from the bottom). If you catch it in time doesn't seem to be permanently damaged.



Floating Point in C

- Converting int to floating point:

```
int value=45;
double temp;

temp=value;           // works
temp=(float)value;   // casts make the conversion explicit
                    // but can potentially hide bugs
```

- float vs double

float is 32-bit, double 64-bit

- Constants 9/5 vs 9.0/5.0

The first is an integer so just “1”. Second is expected



1.8.

- Printing. First prints a double. Second prints a double with only 2 digits after decimal.

```
printf("%f\n",temp);      // print 32-bit float
printf("%lf\n",temp);    // print 64-bit double (long float)
printf("%.2lf\n",temp);  // print double with 2 digits after .
```

- Explicit converting float/double to integer (rather than cast)
 - floor()
 - ceil()
 - round()
 - rint()
 - nearbyint()

