

ECE 571 – Advanced Microprocessor-Based Design Lecture 9

Vince Weaver

`http://www.eece.maine.edu/~vweaver`

`vincent.weaver@maine.edu`

30 September 2014

Announcements

- Next homework coming soon



Bulldozer Paper Review

- Go over the *Bulldozer: An approach to Multithreaded Compute Performance* paper
- In my lab we have a few Piledriver processors (A10-6800B, Opteron 6376) which are improved versions of Bulldozer.
- They care a lot about power usage.
- Also like their FMAC unit a lot.



- This CPU is halfway between CMP and SMT.
- Fused complex ops.
- Can switch threads each cycle
- Branch predictor not described as in-detail as we'd like.



Branch Prediction – Background

- With a pipelined processor, you may have to stall waiting until branch outcome known before you can correctly fetch the next instruction
- Conditional branches are common. On average every 5th instruction?
- One solution is speculative execution.
Guess which way branch goes.
If wrong, in-flight thrown out, have to replay.



- How can get around this?
Try to speculate multiple paths? (rapidly increases).
- Good branch predictors have a 95% or higher hit rate
- **Speculation wastes power**



Static Prediction of Conditional Branches

- Backward taken
- Forward not taken
- Can be used as fallback when there's not more info



Common Access Patterns – For Loop

```
for ( i = 0; i < 100; i ++ ) SOMETHING ;
```

```
    mov r1 , # 100
```

```
label :
```

```
    SOMETHING
```

```
    add r1 , r1 , # - 1
```

```
    bne label
```



Common Access Patterns – While Loop

Optimizing compiler may translate this to a for loop
(why?)

```
x=0; while (x<100) { SOMETHING; x++;}
```

```
    mov r1,#0  
label:  
    cmp r1,#100  
    bge done
```



SOMETHING

```
bne label
```

```
add r1 , r1 , #1
```

```
b label
```

```
done :
```



Common Access Patterns – If/Then

ARM can use predication to avoid this.

```
if (x) { foo } else { bar }
```

```
    cmp r1, #0
```

```
    bne else
```

```
then :
```

```
    foo
```

```
    b done
```

```
else :
```



bar
done :



Branch Prediction Hints

- `likely()` (maps to `__builtin_expect()`)
- `unlikely()`
- on some processors, (p4) hint for static
- others, just move unlikely blocks out of way for better L1I\$ performance



Dynamic Branch Prediction



Branch History Table

- table, likely indexed by lower bits of instruction
can have more advanced indexing to avoid aliasing
no-tag bits, unlike caches aliasing does not affect correct
program execution
- one-bit indicating what the branch did last time
- update when a branch miss happens
- two misses for each time through loop. Wrong at exit of
loop, then wrong again when restarts.



Aliasing

- Is it bad? Good?
- Does the O/S need to save on context switch?
- Do you need to save if entering low-power state?



0x1000 0003 : bne PC+45

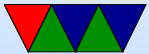
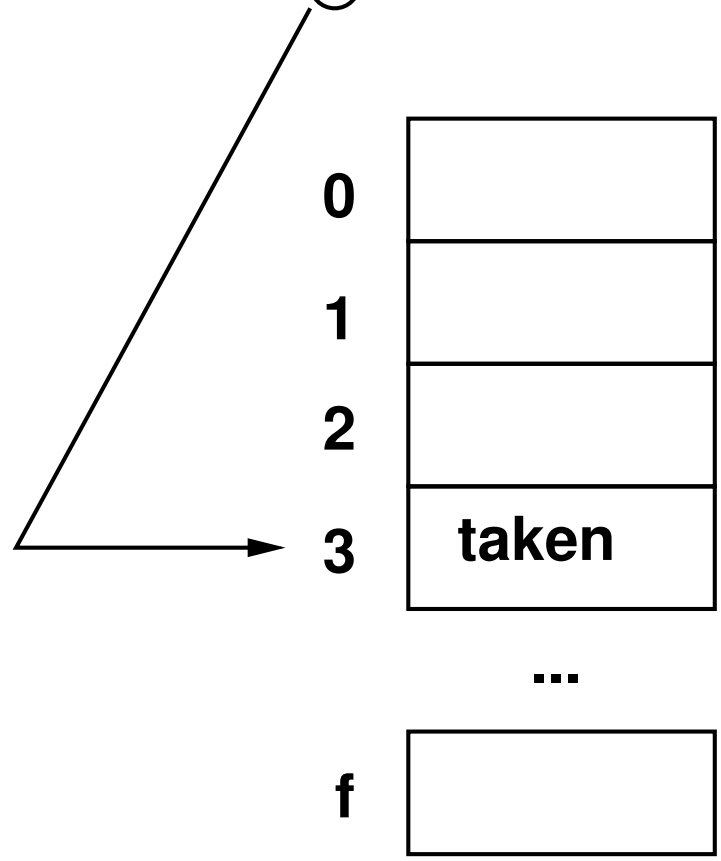

Two-bit saturating counter

- Use saturating 2-bit counter
- If 3/2, predict taken, if 1,0 not-taken. Takes two misses or hits to switch from one extreme to the next, letting loops take only one mispredict.
- Needs to be updated on every branch, not just for a mispredict



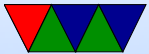
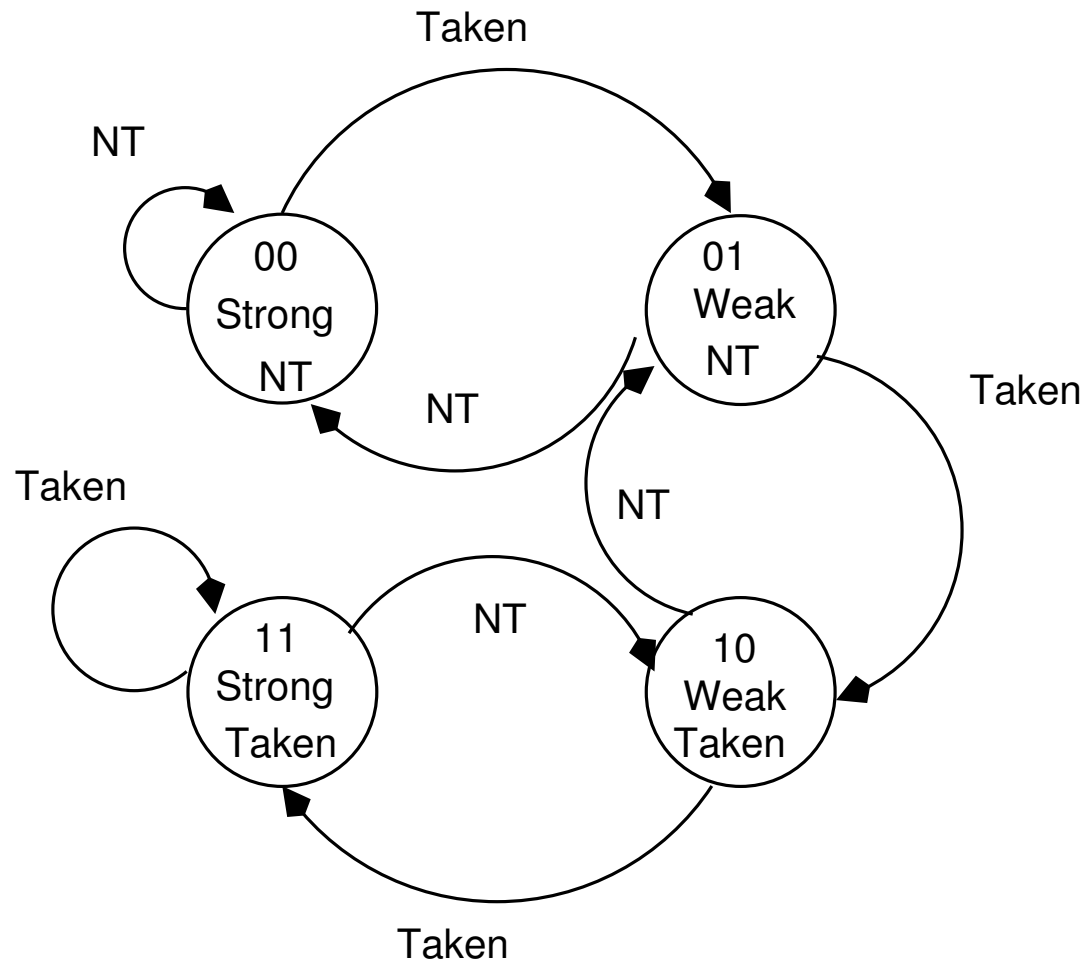

Local vs Global History

- Can use branch history as index into tables
- Use a shift register to hold history
- Global: history is all branches
- Local: store branch history on a branch by branch basis



Global Predictor

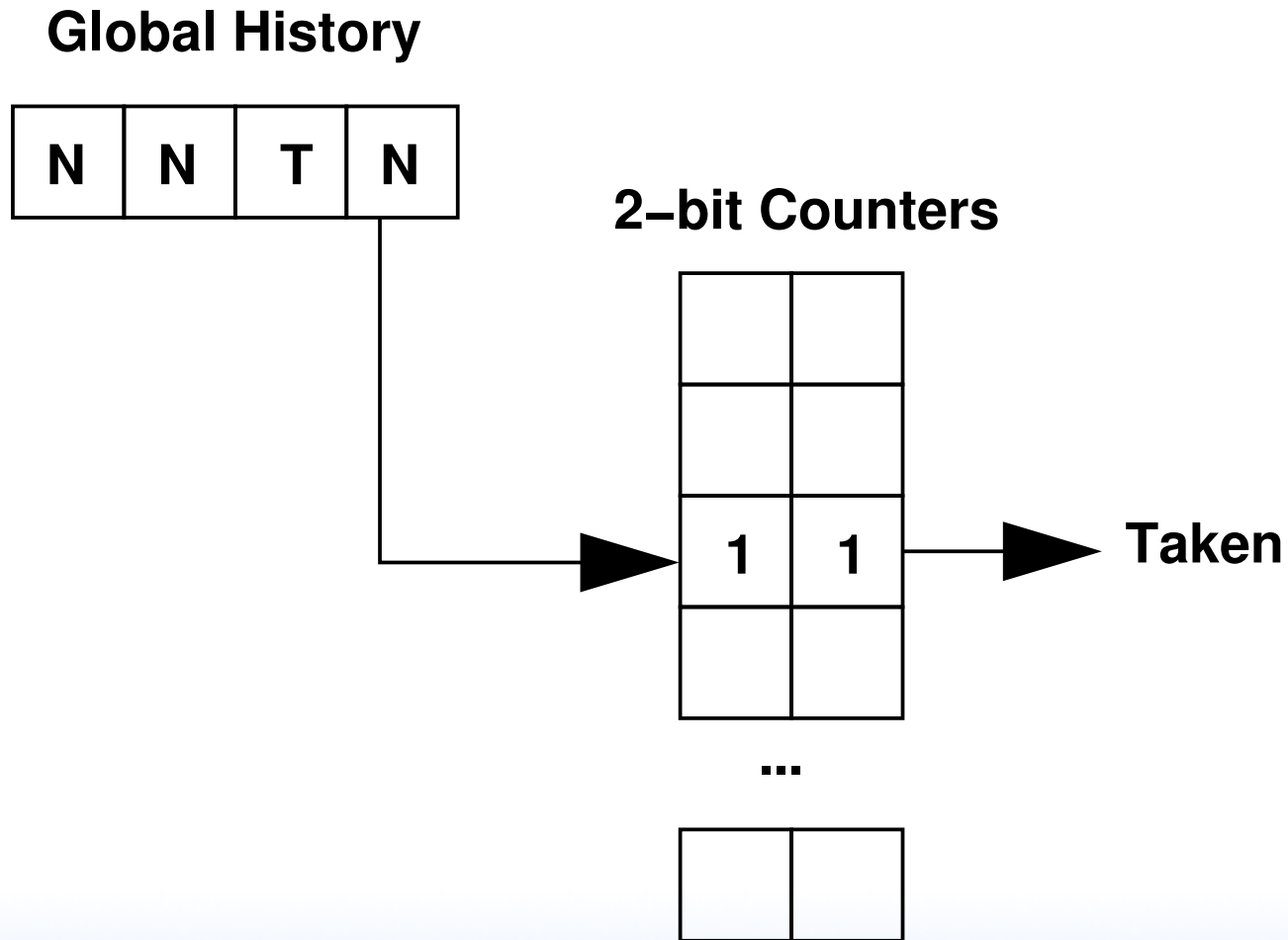

Local Predictor

0x8000 0001 : bne PC+45

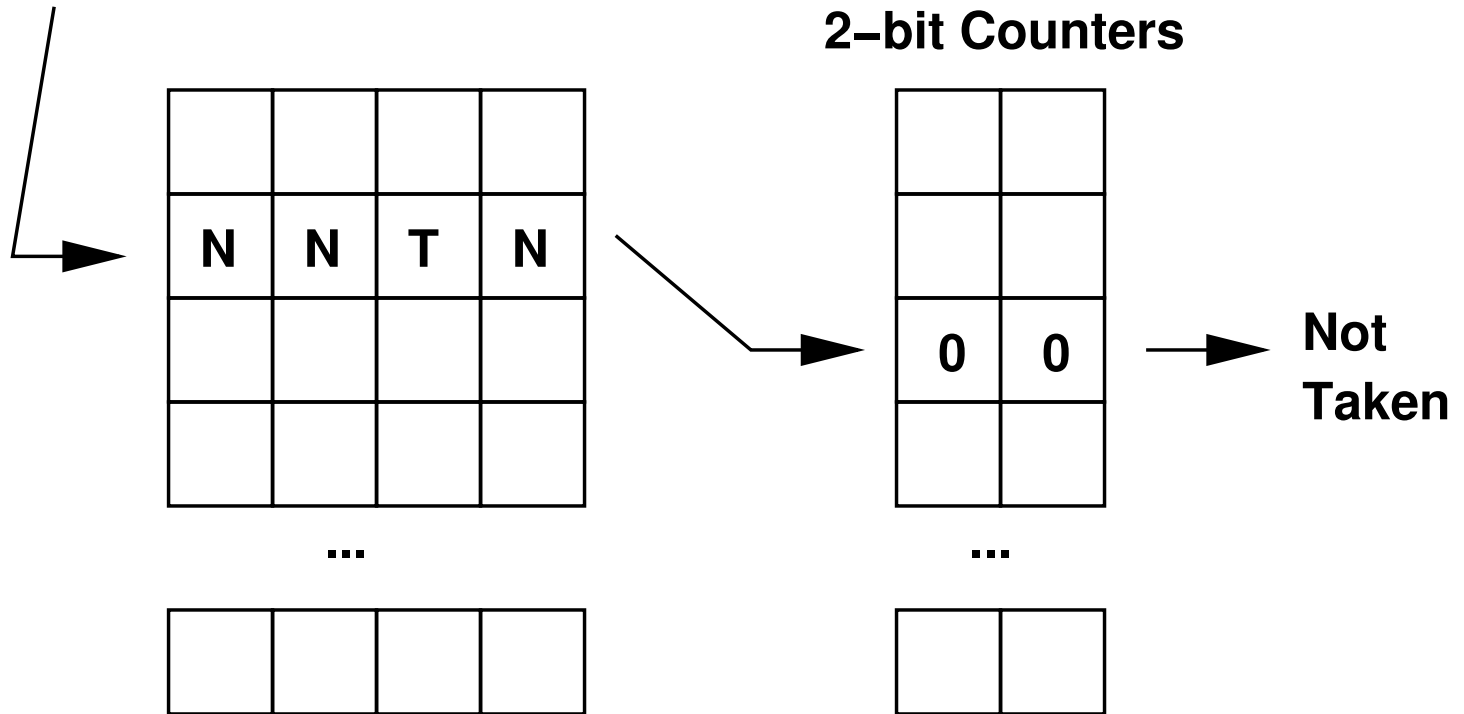

Correlating / Two Level Predictors

- Take history into account.
Break branch prediction for a branch out into multiple locations based on history.

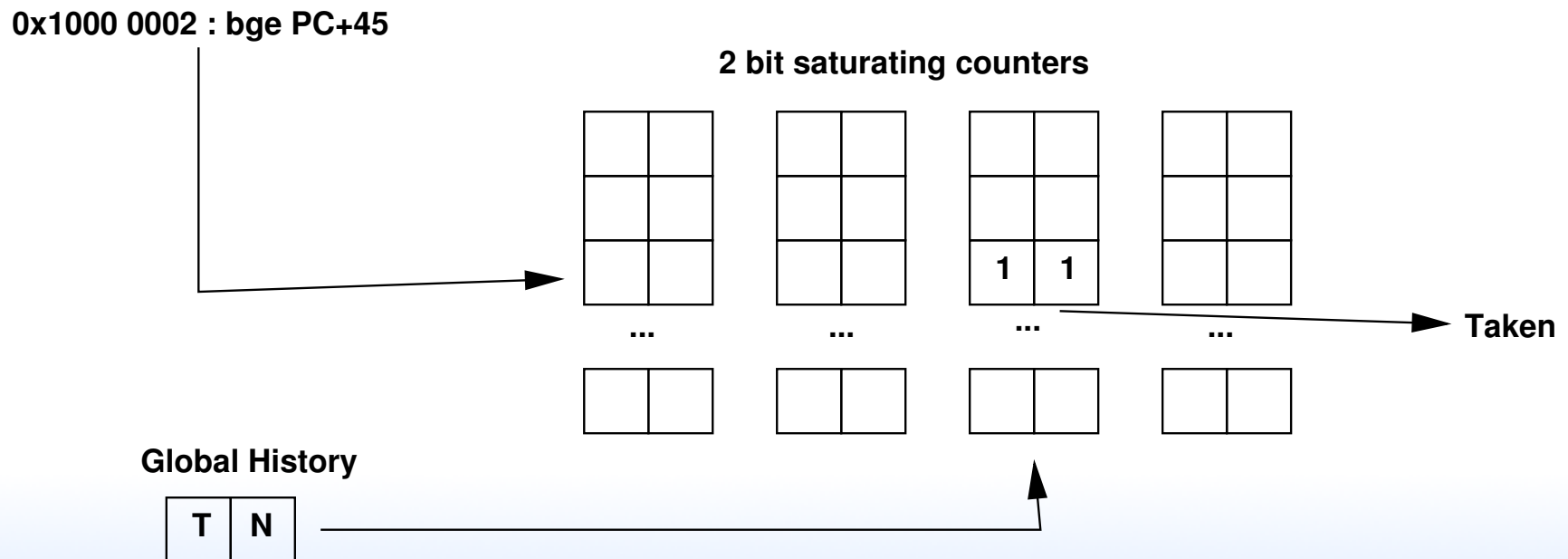

gshare

- Xors the global history with the address bits to get which line to use.
- Benefits of 2-level without the extra circuitry

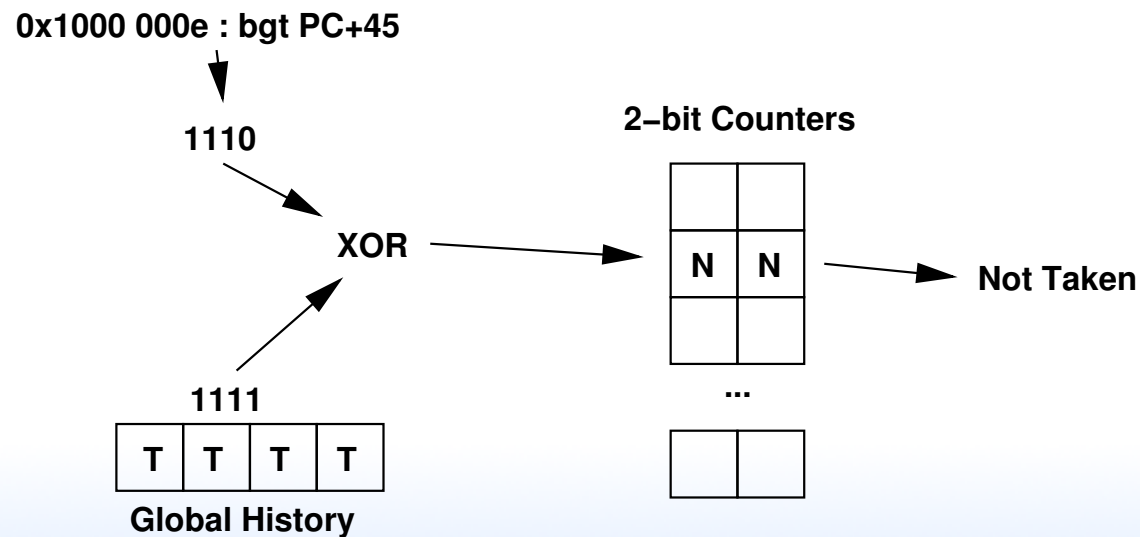

Tournament Predictors

- Which to use? Local or global?
- Have both. How to know which one to use? Predict it!
- 2-bit counter remembers which was best.



Perceptron

- There are actually Branch Prediction Competitions
- The winner the past few times has been a “Perceptron” predictor
- Neural Networks



Comparing Predictors

- Branch miss rate not enough
- Usually the total number of bits needed is factored in
- May also need to keep track of logic needed if it is complex.



Branch Target Buffer

- Predicts the actual destination of addresses.
- Indexed by whole PC. May be looking up before even know it is a branch instruction.
- Only need to store predicted-taken branches. (Why? Because not-taken fall through as per normal).



Return Address Stack

- Function calls can confuse BTB. Multiple locations branching to same spot. Which return address should be predicted?
- Keep a stack of return addresses for function calls
- Playing games with size optimization and fallthrough/tail optimization can confuse.



Adjusting Predictor on the Fly

Some processors let you configure predictor at runtime.

MIPS R12000 let you

ARM possibly does.

Why is this useful?

In theory if you have a known workload you can pick the one that works best.

Also if realtime you want something that is deterministic, like static prediction.

Also Good for simulator validation



Cortex A9 Branch Predictor

From the Manual:

- two-level prediction mechanism, comprising: a two-way BTAC of 512 entries organized as two-way x 256 entries
- a Global History Buffer (GHB) with 4096 2-bit predictors
- a return stack with eight 32-bit entries.
- It is also capable of predicting state changes from ARM to Thumb, and from Thumb to ARM.



Example

Code in perf_event validation tests for generic events.

http://web.eece.maine.edu/~vweaver/projects/perf_events/validation/



Example Results



Part 1

Testing a loop with 1500000 branches (100 times):

On a simple loop like this, miss rate should be very small.

Adjusting domain to 0,0,0 for ARM

Average number of branch misses: 685

Part 2

Adjusting domain to 0,0,0 for ARM

Testing a function that branches based on a random number

The loop has 7710798 branches.

500000 are random branches; 250699 of those were taken

Adjusting domain to 0,0,0 for ARM

Out of 7710798 branches, 291081 were mispredicted

Assuming a good random number generator and no freaky luck

The mispredicts should be roughly between 125000 and 375000

Testing ‘‘branch-misses’’ generalized event...

PASSED



Value Prediction

- Can we use this mechanism to help other performance issues?
What about caches?
- Can we predict values loaded from memory?
- Load Value Prediction. You can, sometimes with reasonable success, but apparently not worth trouble as no vendors have ever implemented it.

