

# **ECE 571 – Advanced Microprocessor-Based Design Lecture 10**

Vince Weaver

`http://www.eece.maine.edu/~vweaver`

`vincent.weaver@maine.edu`

18 February 2016

# Announcements

- HW#5 Will be Posted, Caches



# Cache Example Two

512 Byte cache, 2-Way Set Associative, with 16 byte lines, LRU replacement.

24-bit tag, 16 lines (4 bits), 4-bit offset.

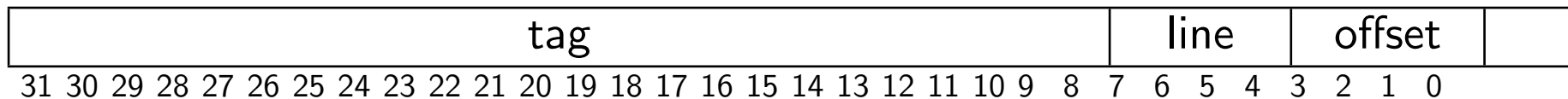

# Cache Example 2



# Cache Example – Instruction 1

```
ldrb r1, 0x00000000
```

	Way 0				Way 1			
line	V	D	LRU	Tag	V	D	LRU	Tag
0	1	0	0	0000 00	0			
1	0				0			
2	0				0			
3	0				0			
4	0				0			
5	0				0			
...								
b	0				0			
c	0				0			
d	0				0			
e	0				0			
f	0				0			

Miss, Cold



# Cache Example – Instruction 2

`str r1, 0x00000001`

	Way 0				Way 1			
line	V	D	LRU	Tag	V	D	LRU	Tag
0	1	1	0	0000 00	0			
1	0				0			
2	0				0			
3	0				0			
4	0				0			
5	0				0			
...								
b	0				0			
c	0				0			
d	0				0			
e	0				0			
f	0				0			

Hit

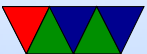

# Cache Example – Instruction 3

strb r1, 0x00000105

	Way 0				Way 1			
line	V	D	LRU	Tag	V	D	LRU	Tag
0	1	1	1	0000 00	1	1	0	0000 01
1	0				0			
2	0				0			
3	0				0			
4	0				0			
5	0				0			
...								
b	0				0			
c	0				0			
d	0				0			
e	0				0			
f	0				0			

Miss, Cold

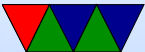

# Cache Example – Instruction 4

```
ldr r1, 0x00000206
```

	Way 0				Way 1			
line	V	D	LRU	Tag	V	D	LRU	Tag
0	1	0	0	0000 02	1	1	1	0000 01
1	0				0			
2	0				0			
3	0				0			
4	0				0			
5	0				0			
...								
b	0				0			
c	0				0			
d	0				0			
e	0				0			
f	0				0			

Miss, Cold





# Cache Example – Instruction 5

ldb r1, 0x00000000

	Way 0				Way 1			
line	V	D	LRU	Tag	V	D	LRU	Tag
0	1	0	1	0000 02	1	0	0	0000 00
1	0				0			
2	0				0			
3	0				0			
4	0				0			
5	0				0			
...								
b	0				0			
c	0				0			
d	0				0			
e	0				0			
f	0				0			

Miss, Conflict



# Cache Example – Instruction 6

ldb r1, 0x00000030

	Way 0				Way 1			
line	V	D	LRU	Tag	V	D	LRU	Tag
0	1	0	1	0000 02	1	0	0	0000 00
1	0				0			
2	0				0			
3	1	0	0	0000 00	0			
4	0				0			
5	0				0			
...								
b	0				0			
c	0				0			
d	0				0			
e	0				0			
f	0				0			

Miss, Cold



# CMP Issues



# Cache Coherency

- Protocols such as MESI (Modified, Exclusive, Shared, Invalid)
- Snoopy vs Directory



# Cortex A9 Cache Layout

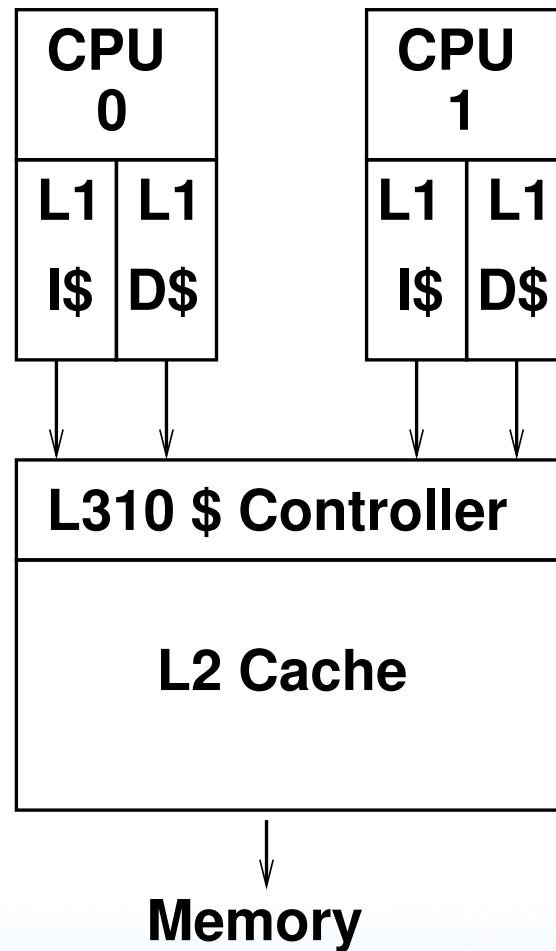

# Cortex A9 Cache Layout

- OMAP4430 processor
- 32kB 4-way associative, separate L1-I and L1-D
  - pseudo-round-robin or pseudo random replacement
  - 8-word line size (32B)
  - critical-word first filling
  - instruction: VIPT, data: PIPT
- Optional L2 cache controller
  - Pandaboard has L310 L2 cache controller, 1MB 16-way



## Optional prefetcher

- data cache reads/writes non-blocking, 4 outstanding misses  
write buffer: 4 64-bit, allowing write combining



# SandyBridge Cache Layout

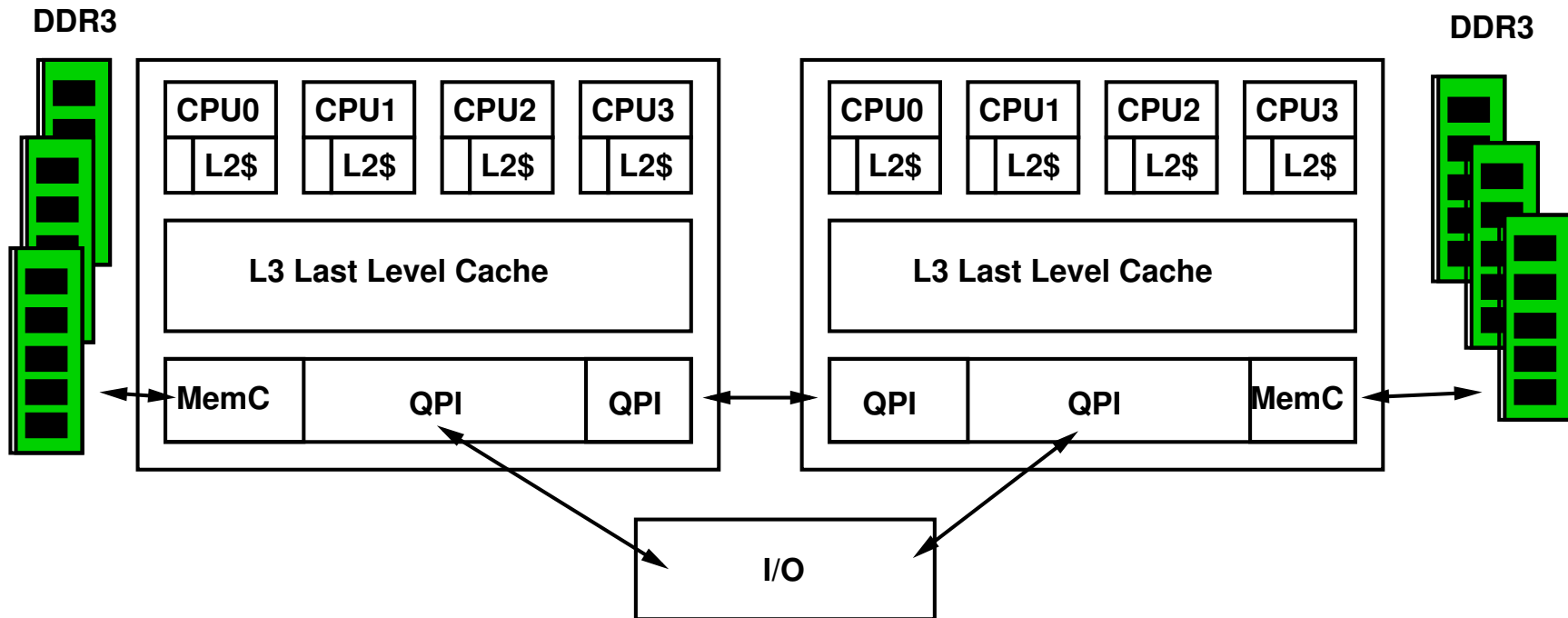



# SandyBridge Cache Layout

- per core 32kB L1 I/D – 4 clocks  
64B/line, 8-Way  
(shared if hyper-threaded)  
writeback
- mOp cache? 1.5K instructions, 8-way, 6Mop/line  
Loop stream detector, can execute w/o accessing icache
- per core 256kB L2 unified – 12 clocks



64B/line, 8-way  
writeback. non-inclusive

- shared L3 1MB-20MB – 26-31 clocks  
64B/line. 12-way (varies)  
writeback, inclusive
- various hw prefetchers operating



# Cache Performance Measurement

Matrix-Matrix multiply is the typical example.

Despite being a big deal in HPC, MMM happens in embedded world too.



# Naive Matrix-Matrix Multiply 1

```
#define MATRIX_SIZE 512
static double a[MATRIX_SIZE][MATRIX_SIZE];
static double b[MATRIX_SIZE][MATRIX_SIZE];
static double c[MATRIX_SIZE][MATRIX_SIZE];

for(j=0; j<MATRIX_SIZE; j++) {
    for(i=0; i<MATRIX_SIZE; i++) {
        for(k=0; k<MATRIX_SIZE; k++) {
            c[i][j] += a[i][k] * b[k][j];
        }
    }
}
```



# Naive Matrix-Matrix Multiply 1 – what's the issue?

- Branch Misses?
- TLB Misses?
- ICache Misses?
- DCache Misses?
- L2 Cache Misses?



# Naive Matrix-Matrix Multiply 1 – perf results



Matrix multiply sum: s=27665734022509.746094

Performance counter stats for './matrix\_multiply':

11296.203614	task-clock	#	0.999 CPUs utilized
20	context-switches	#	0.000 M/sec
0	CPU-migrations	#	0.000 M/sec
1,633	page-faults	#	0.000 M/sec
9,032,356,979	cycles	#	0.800 GHz
6,547,102	stalled-cycles-frontend	#	0.07% frontend cycles id
8,213,005,758	stalled-cycles-backend	#	90.93% backend cycles id
1,176,144,886	instructions	#	0.13 insns per cycle
		#	6.98 stalled cycles per
137,651,296	branches	#	12.186 M/sec
795,064	branch-misses	#	0.58% of all branches
11.303802490	seconds time elapsed		



# Naive Matrix-Matrix Multiply 1 – DCache results

```
vince@arm:~/class/ece571/lecture10_code$ perf stat -e cache-misses,cache-r  
Matrix multiply sum: s=27665734022509.746094
```

```
Performance counter stats for './matrix_multiply':
```

```
171,786,441 cache-misses          # 42.072 % of all cache ref  
408,318,876 cache-references
```

```
10.680664062 seconds time elapsed
```





# Naive Matrix-Matrix Multiply 1 – ICache results

```
vince@arm:~/class/ece571/lecture10_code$ perf stat -e l1-icache-load-misses  
Matrix multiply sum: s=27665734022509.746094
```

```
Performance counter stats for './matrix_multiply':
```

```
          536,719 l1-icache-load-misses  
1,174,927,869 instructions                #    0.00  insns per cycle
```

```
12.203002930 seconds time elapsed
```

```
0.04% icache misses
```



# Naive Matrix-Matrix Multiply 1 – TLB Misses

```
vince@arm:~/class/ece571/lecture10_code$ perf stat -e dTLB-load-misses,dTLB-store-misses ./matrix_multiply  
Matrix multiply sum: s=27665734022509.746094
```

```
Performance counter stats for './matrix_multiply':
```

```
135,253,464 dTLB-load-misses
```

```
135,253,464 dTLB-store-misses
```

```
12.443572998 seconds time elapsed
```



# Naive Matrix-Matrix Multiply 1 – What's the Issue?

400M memory accesses about right ( $512 \times 512 \times 512 \times 3$ )

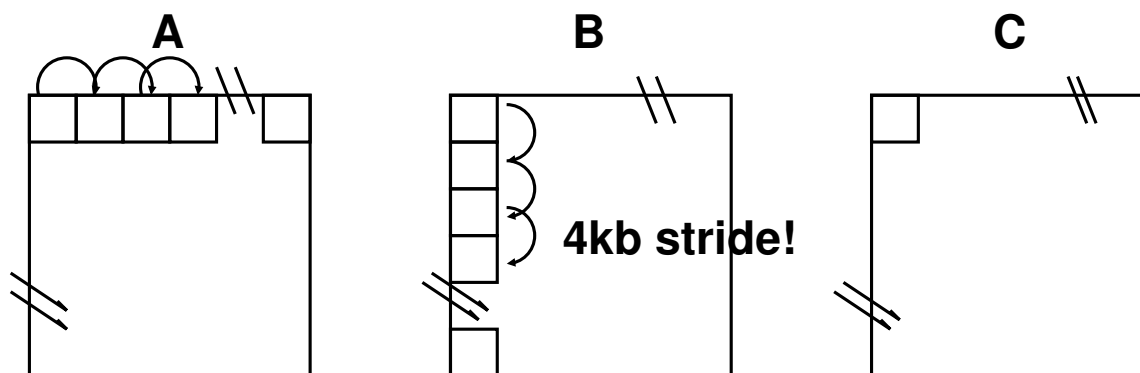

# Switch the loop ordering

```
for (i=0; i<MATRIX_SIZE; i++) {  
  for (k=0; k<MATRIX_SIZE; k++) {  
    for (j=0; j<MATRIX_SIZE; j++) {  
      c[i][j] += a[i][k] * b[k][j];  
    }  
  }  
}
```

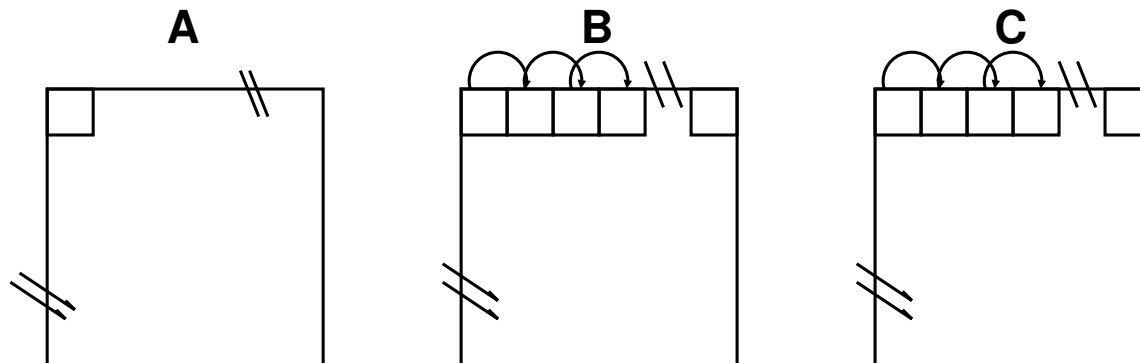

# Naive Matrix-Matrix Multiply 2 – perf results



Matrix multiply sum: s=27665734022509.746094

Performance counter stats for './matrix\_multiply\_swapped':

3443.267822	task-clock	#	0.999 CPUs utilized
5	context-switches	#	0.000 M/sec
0	CPU-migrations	#	0.000 M/sec
1,633	page-faults	#	0.000 M/sec
2,849,573,010	cycles	#	0.828 GHz
2,913,607	stalled-cycles-frontend	#	0.10% frontend cycles id
1,893,138,507	stalled-cycles-backend	#	66.44% backend cycles id
965,962,767	instructions	#	0.34 insns per cycle
		#	1.96 stalled cycles per
136,649,964	branches	#	39.686 M/sec
553,643	branch-misses	#	0.41% of all branches
3.447875977	seconds time elapsed		



# Naive Matrix-Matrix Multiply 2 – DCache results

```
vince@arm:~/class/ece571/lecture10_code$ perf stat -e cache-misses,cache-r  
Matrix multiply sum: s=27665734022509.746094
```

```
Performance counter stats for './matrix_multiply_swapped':
```

```
    38,628,043 cache-misses          #    9.409 % of all cache ref  
  410,528,663 cache-references  
  
    5.585754395 seconds time elapsed
```



# Naive Matrix-Matrix Multiply 2 – ICache results

```
vince@arm:~/class/ece571/lecture10_code$ perf stat -e l1-icache-load-misses  
Matrix multiply sum: s=27665734022509.746094  
  
Performance counter stats for './matrix_multiply_swapped':  
  
      254,041 l1-icache-load-misses  
964,335,795 instructions          #    0.00  insns per cycle  
  
4.245208740 seconds time elapsed  
  
0.02%
```





# Naive Matrix-Matrix Multiply 1 – TLB Misses

```
vince@arm:~/class/ece571/lecture10_code$ perf stat -e dTLB-load-misses,dTLB-store-misses ./matrix_multiply_swapped
Matrix multiply sum: s=27665734022509.746094
```

```
Performance counter stats for './matrix_multiply_swapped':
```

```
486,039 dTLB-load-misses
```

```
486,039 dTLB-store-misses
```

```
5.242126465 seconds time elapsed
```



# Other Ways to Optimize

- Tiling
- Parallelizing



# Use ATLAS/BLAS

```
cblas_dgemm(CblasRowMajor ,  
            CblasNoTrans ,CblasNoTrans ,  
            512,512,512 ,  
            1.0,(const double *)a,512 ,  
            (const double *)b,512 ,  
            1.0,(double *)c,512);
```



# Matrix-Matrix Mul ATLAS – perf results

```
Matrix multiply sum: s=27665734022509.746094
```

```
Performance counter stats for './matrix_multiply_atlas':
```

```
1158.325193 task-clock # 1.678 CPUs utilized
      12 context-switches # 0.000 M/sec
        1 CPU-migrations # 0.000 M/sec
    2,017 page-faults # 0.002 M/sec
597,931,712 cycles # 0.516 GHz
  2,043,500 stalled-cycles-frontend # 0.34% frontend cycles id
258,860,537 stalled-cycles-backend # 43.29% backend cycles id
519,715,833 instructions # 0.87 insns per cycle
                                # 0.50 stalled cycles per
 36,716,368 branches # 31.698 M/sec
    815,440 branch-misses # 2.22% of all branches

0.690429687 seconds time elapsed
```



# Matrix-Matrix Mul ATLAS – DCache

```
Matrix multiply sum: s=27665734022509.746094
```

```
Performance counter stats for './matrix_multiply_atlas':
```

```
    11,988,047 cache-misses          #    8.128 % of all cache ref  
  147,494,664 cache-references  
  
0.598632813 seconds time elapsed
```



# Matrix-Matrix Mul ATLAS – TLB

```
vince@arm:~/class/ece571/lecture10_code$ perf stat -e dTLB-load-misses ./m  
Matrix multiply sum: s=27665734022509.746094
```

```
Performance counter stats for './matrix_multiply_atlas':
```

```
224,299 dTLB-load-misses
```

```
0.755981446 seconds time elapsed
```

